

A = STRAIGHT ENTRY

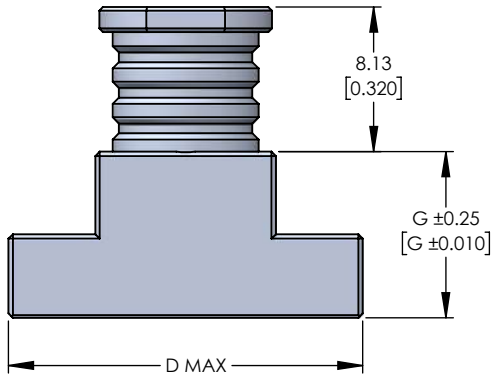

B = 90° ENTRY

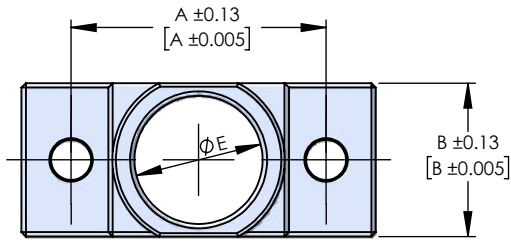
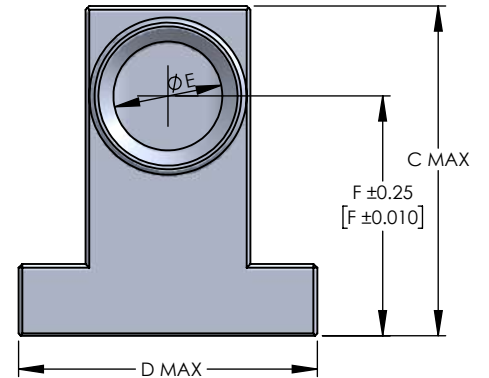
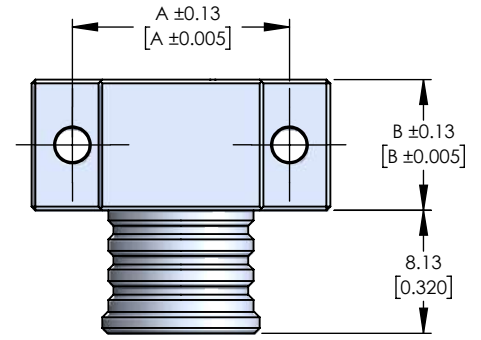

ORDERING INFORMATION

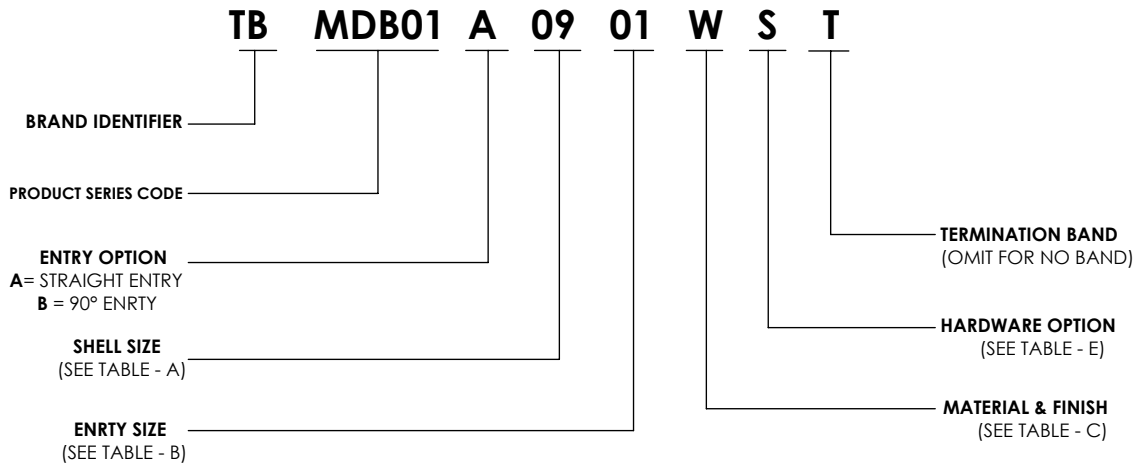

TURBO INDIA

INTERCONNECT SOLUTIONS
#114, 1st Floor, P C Industrial Estate, Kamakshipalya,
Magadi Rd, Bangalore 560 079, Karnataka, India

THIS DRAWING IS COPYRIGHT AND THE PROPERTY OF TURBO INDIA INTERCONNECT SOLUTIONS. IT MUST NOT BE COPIED, USED FOR MANUFACTURE OR OTHERWISE DISCLOSED WITHOUT PRIOR WRITTEN CONSENT OF THE COMPANY.

UNLESS OTHERWISE SPECIFIED : ALL DIMENSIONS IN MILLIMETRES
GENERAL TOL:
LINEAR : ± 0.10MM
ANGULAR : ± 2°

MATERIAL :	---
WEIGHT :	---

REV.No
01

ASSEMBLY USED ON:
M83513 Connectors

DESCRIPTION : MICRO-D EMI BACKSHELLS CIRCULAR ENTRY

PART NUMBER / SERIES:
SERIES MDB01

PAGE:NO
80

SHELL SIZE (TABLE - A)

SHELL SIZE	A ± 0.13 (±.005)	B ± 0.13 (±.005)	C MAX	D MAX	F ± 0.25 (±.010)	G ± 0.25 (±.010)
09	14.35 (0.565)	8.64 (0.340)	21.97 (0.865)	19.94 (0.785)	15.88 (0.625)	11.04 (0.434)
15	18.16 (0.715)	8.64 (0.340)	21.97 (0.865)	23.75 (0.935)	15.88 (0.625)	12.49 (0.491)
21	21.97 (0.865)	8.64 (0.340)	21.97 (0.865)	27.56 (1.085)	15.88 (0.625)	13.76 (0.541)
25	24.51 (0.965)	8.64 (0.340)	21.97 (0.865)	30.10 (1.185)	15.88 (0.625)	15.03 (0.591)
31	28.32 (1.115)	8.64 (0.340)	21.97 (0.865)	33.91 (1.335)	15.88 (0.625)	16.05 (0.631)
37	32.13 (1.265)	8.64 (0.340)	21.97 (0.865)	37.72 (1.485)	15.88 (0.625)	17.07 (0.672)
51	30.86 (1.215)	10.16 (0.400)	21.97 (0.865)	36.45 (1.435)	15.88 (0.625)	19.19 (0.755)
69	34.48 (1.515)	10.16 (0.400)	23.50 (0.925)	44.07 (1.735)	16.38 (0.645)	19.86 (0.781)
100	45.72 (1.800)	11.43 (0.450)	24.39 (0.960)	55.25 (2.175)	16.69 (0.657)	20.75 (0.816)

ENTRY SIZE (TABLE - B)

ENTRY SIZE	E ±0.25 (±0.010)	FOR SHELL SIZES
01	7.21 (0.284)	09 - 100
02	8.74 (0.344)	15 - 100
03	9.75 (0.384)	100

MATERIAL & FINISH (TABLE - C)

CODE	BASE MATERIAL	FINISH DESCRIPTION
A	Aluminium	Anodize Black
W		Cadmium Olive Drab over Electroless Nickel
N		Electroless Nickel
Z		Zinc Nickel Black
CF		Chromite Conversion - Yellow

HARDWARE OPTION (TABLE - E)

CODE	Description	Items in kit
J	Jackpost	Jackpost - 2 Nos Teeth Washers - 2 Nos Lock nut - 2 Nos
H	Hexagonal Headed Jackscrew - Low profile	Hex headed Jack screw - 2 Nos E-Retaining Rings - 2 Nos
S	Slot Headed Jackscrew - Low profile	Slot Headed Jack screw - 2 Nos E-Retaining Rings - 2 Nos
EX	Hexagonal Headed Jackscrew - Extended	Hex headed Jack screw - 2 Nos E-Retaining Rings - 2 Nos
E	Slot Headed Jackscrew - Extended	Slot Headed Jack screw - 2 Nos E-Retaining Rings - 2 Nos

Custom Hardware options can be provided on request.
For customisation mail to us on sales@turboindia.co.in

DIMENSIONS IN PARENTHESIS ARE IN INCHES.

**HARDWARE OPTION - S
(FOR REFERENCE ONLY)**

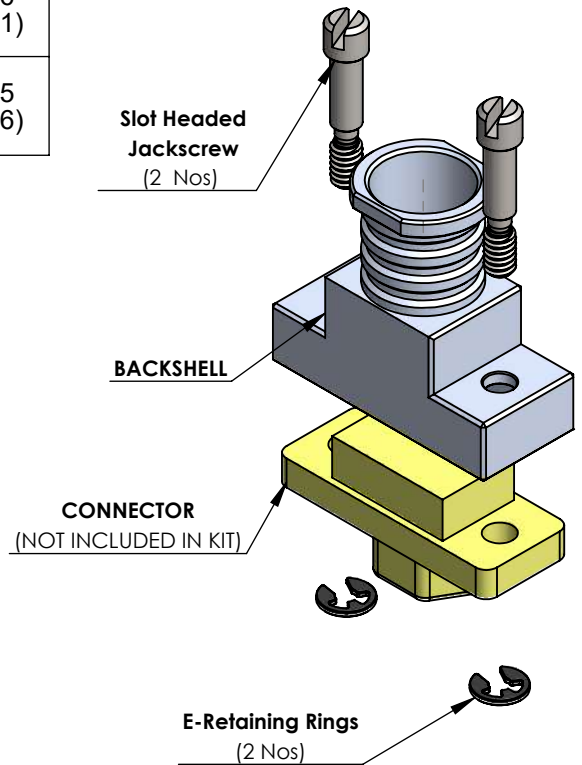

TURBO INDIA

INTERCONNECT SOLUTIONS
#114, 1st Floor, P C Industrial Estate, Kamakshipalya,
Magadi Rd, Bangalore 560 079, Karnataka, India

THIS DRAWING IS COPYRIGHT AND THE PROPERTY OF TURBO INDIA INTERCONNECT SOLUTIONS. IT MUST NOT BE COPIED, USED FOR MANUFACTURE OR OTHERWISE DISCLOSED WITHOUT PRIOR WRITTEN CONSENT OF THE COMPANY.

UNLESS OTHERWISE SPECIFIED :
ALL DIMENSIONS IN MILLIMETRES
GENERAL TOL:
LINEAR : ± 0.10MM
ANGULAR : ± 2°

MATERIAL :	---	REV.No 01
WEIGHT :	---	
ASSEMBLY USED ON: M83513 Connectors		

DESCRIPTION : MICRO-D EMI BACKSHELLS CIRCULAR ENTRY	
PART NUMBER / SERIES: SERIES MDB01	PAGE:NO 81